

HB 90

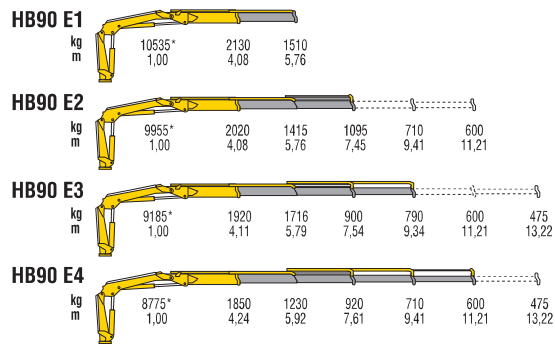

*) Theoretical lifting capacity

MODELS	LIFTING MOMENT	MAX VERTICAL REACH (HYDR)	SLEWING ANGLE	SLEWING TIME	MAX WORKING HEEL	WORKING PRESSURE	CRANE WEIGHT WITHOUT STABILIZERS	OIL TANK CAPACITY	OIL FLOW	DIMENSIONS
	tm	m	°	s/180°	°	bar	kg	l	l/min	mm B x h x S
HB90 E1	8,7	9,1	425	20	4	310	1030	75	40	2305X2070X800
HB90 E2	-	10,7	425	20	4	310	1110	75	40	2305X2070X800
HB90 E3	-	12,6	425	20	4	310	1190	75	40	2305X2070X800
HB90 E4	-	14,4	425	20	4	310	1260	75	40	2305X2070X800